

# Kettenradscheibe 05B-1

für Simplex-Rollenkette  
nach DIN 8187 - ISO/R 606 B  
Verzahnung nach DIN 8196-1

Teilung:	8,0	mm
Lichte Weite:	3,0	mm
Zahnradius (r):	8,0	mm
Zahnbreite (Z <sub>b</sub> ):	2,8	mm
Radialbreite (C):	1,0	mm
Rollendurchmesser:	5,0	mm
Material:	C45	



Simplex Kettenradscheibe

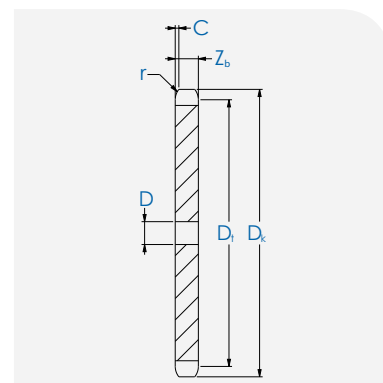

Querschnitt



Bezeichnung	Zähnezahl		Abmessungen			Gewicht kg
	Z	D <sub>k</sub> mm	D <sub>t</sub> mm	D mm		
KRS05B-1-Z008	8	24	20,9	6	-	
KRS05B-1-Z009	9	26,6	23,39	6	-	
KRS05B-1-Z010	10	29,2	25,89	8	-	
KRS05B-1-Z011	11	31,7	28,39	8	-	
KRS05B-1-Z012	12	34,2	30,91	8	-	
KRS05B-1-Z013	13	36,7	33,42	8	-	
KRS05B-1-Z014	14	39,2	35,95	8	-	
KRS05B-1-Z015	15	41,7	38,48	8	-	
KRS05B-1-Z016	16	44,3	41,01	8	-	
KRS05B-1-Z017	17	46,8	43,53	8	-	
KRS05B-1-Z018	18	49,3	46,07	8	-	
KRS05B-1-Z019	19	51,9	48,31	8	-	
KRS05B-1-Z020	20	54,4	51,14	8	-	
KRS05B-1-Z021	21	57	53,67	8	-	
KRS05B-1-Z022	22	59,5	56,21	8	-	
KRS05B-1-Z023	23	62	58,75	8	-	
KRS05B-1-Z024	24	64,6	61,29	8	-	
KRS05B-1-Z025	25	67,5	63,83	8	-	
KRS05B-1-Z026	26	69,5	66,37	10	-	
KRS05B-1-Z027	27	72,2	68,91	10	-	
KRS05B-1-Z028	28	74,8	71,45	10	-	
KRS05B-1-Z029	29	77,3	73,99	10	-	
KRS05B-1-Z030	30	79,8	76,53	10	-	
KRS05B-1-Z031	31	82,4	79,08	10	-	
KRS05B-1-Z032	32	84,9	81,61	10	-	
KRS05B-1-Z033	33	87,5	84,16	10	-	
KRS05B-1-Z034	34	90	86,7	10	-	
KRS05B-1-Z035	35	92,5	89,24	10	-	
KRS05B-1-Z036	36	95	91,79	10	-	
KRS05B-1-Z037	37	97,6	94,33	10	-	
KRS05B-1-Z038	38	100,2	96,88	10	-	
KRS05B-1-Z039	39	102,7	99,42	10	-	
KRS05B-1-Z040	40	105,2	101,97	10	-	
KRS05B-1-Z041	41	107,8	104,51	12	-	
KRS05B-1-Z042	42	110,4	107,05	12	-	
KRS05B-1-Z043	43	112,9	109,6	12	-	
KRS05B-1-Z044	44	115,5	112,14	12	-	
KRS05B-1-Z045	45	118	114,69	12	-	
KRS05B-1-Z046	46	120,6	117,23	12	-	
KRS05B-1-Z047	47	123,1	119,77	12	-	

# Kettenradscheibe 05B-1

für Simplex-Rollenkette  
nach DIN 8187 - ISO/R 606 B  
Verzahnung nach DIN 8196-1

Teilung:	8,0	mm
Lichte Weite:	3,0	mm
Zahnradius (r):	8,0	mm
Zahnbreite ( $Z_b$ ):	2,8	mm
Radialbreite (C):	1,0	mm
Rollendurchmesser:	5,0	mm
Material:	C45	



Simplex Kettenradscheibe

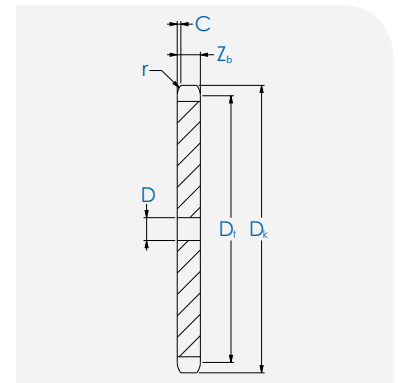

Querschnitt



Bezeichnung	Zähnezahl		Abmessungen			Gewicht kg
	Z		$D_k$ mm	$D_t$ mm	D mm	
KRS05B-1-Z048	48		125,6	122,32	12	-
KRS05B-1-Z049	49		128,2	124,86	12	-
KRS05B-1-Z050	50		130,7	127,41	12	-
KRS05B-1-Z051	51		133,3	129,95	14	-
KRS05B-1-Z052	52		135,8	132,49	14	-
KRS05B-1-Z053	53		138,4	135,04	14	-
KRS05B-1-Z054	54		140,9	137,59	14	-
KRS05B-1-Z055	55		143,5	140,13	14	-
KRS05B-1-Z056	56		146	142,68	14	-
KRS05B-1-Z057	57		148,6	145,22	14	-
KRS05B-1-Z058	58		151	147,77	14	-
KRS05B-1-Z059	59		153,6	150,31	14	-
KRS05B-1-Z060	60		156,2	152,85	14	-
KRS05B-1-Z062	62		162	157,95	16	-
KRS05B-1-Z064	64		167,1	163,04	16	-
KRS05B-1-Z065	65		169,2	165,58	16	-
KRS05B-1-Z066	66		172,2	168,13	16	-
KRS05B-1-Z068	68		177,3	173,22	16	-
KRS05B-1-Z070	70		182,4	178,31	16	-
KRS05B-1-Z072	72		187,5	183,41	20	-
KRS05B-1-Z075	75		195,1	191,04	20	-
KRS05B-1-Z076	76		197,7	193,59	20	-
KRS05B-1-Z078	78		202,8	198,68	20	-
KRS05B-1-Z080	80		207,9	203,77	20	-
KRS05B-1-Z085	85		220,6	216,5	20	-
KRS05B-1-Z090	90		233,4	229,23	20	-
KRS05B-1-Z095	95		246,1	241,96	20	-
KRS05B-1-Z100	100		258,9	254,68	20	-
KRS05B-1-Z110	110		284,3	280,15	20	-
KRS05B-1-Z114	114		294,5	290,33	20	-
KRS05B-1-Z120	120		310	305,61	20	-
KRS05B-1-Z125	125		322,5	318,34	20	-